

LIGHT EMITTING DIODE SPECIFICATION

DESCRIPTION: XT1-3014BWOY-AN

REVISION : V1.2

ISSUE DATE : 2012/01/30

Revision Note

Date	Revision	Page	Version
2010/08/13	Initiate Document	1~12	V1.0
2011/08/15	Specification updated	1~11	V1.1
2012/01/30	Specification updated	1~11	V1.2

Lighting LED Specification

XT1-3014BWOY-AN

Warm - White LED Specification

Features

- ◆ Feature of the device: Small package with high efficiency
- ◆ Typical color temperature: 3000 K.
- ◆ Typical view angle: 120°
- ◆ Typical light output: 3000mcd @ 30mA.
- ◆ Soldering methods: SMT
- ◆ Grouping parameter: Brightness, Forward Voltage and Chromaticity.
- ◆ Color rendering Index: 70(min.)
- ◆ The product itself will remain within RoHS compliant version.



Applications

- ◆ T8/T5 tube applied
- ◆ Linear lighting source
- ◆ Plate lighting source
- ◆ Retrofit

Materials

Items	Description
Substrate	PPA with Metal Heat Sink
Housing	Heat resistant polymer
Encapsulating Resin	Silicone resin
Electrodes	Ag plating copper alloy
Die attach	Thermal conductive paste
Chip	InGaN

Dimensions

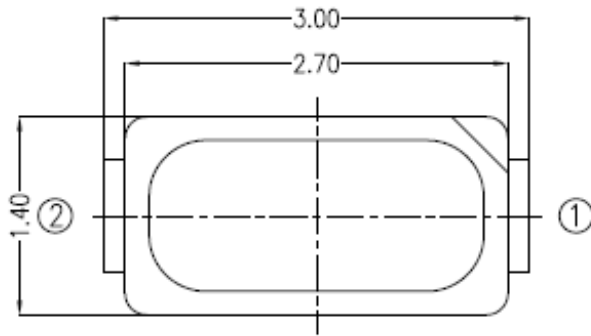

Polarity

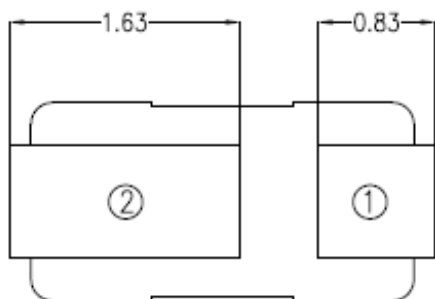
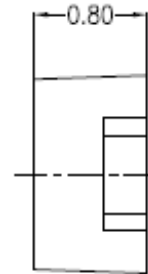

Bot view

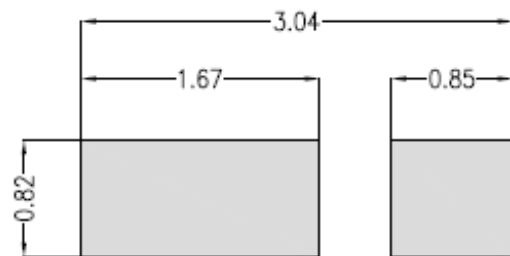

Soldering patterns

Note.

1. Dimensions are in millimeters.
2. Tolerances for fixed dimensions are ± 0.1 mm.

Absolute Maximum Ratings ($T_A=25^{\circ}\text{C}$)

Parameter	Symbol	Rating	Unit
DC Forward Current	I_{FD}	35	mA
Peak Pulse Current ($t_p \leq 10\text{ms}$, Duty cycle = 1/10)	I_{FP}	100	mA
Reverse Voltage	V_R	5	V
LED Junction Temperature	T_j	110	$^{\circ}\text{C}$
Operation Temperature	T_{opr}	-40~80	$^{\circ}\text{C}$
Storage Temperature	T_{stg}	-40~80	$^{\circ}\text{C}$
Peak Soldering Temperature	T_{sol}	260 $^{\circ}$	$^{\circ}\text{C}$

Electrical-Optical Characteristics For Individual LED ($T_A = 25^{\circ}\text{C}$)

Parameter	Symbol	Bin	Min	Max	Unit	Condition
Brightness ₍₁₎	I_v	A	2100	2400	mcd	$I_F = 30\text{mA}$
		B	2400	2600		
		C	2600	2800		
		D	2800	3000		
		E	3000	3200		
		F	3200	3600		
		G	3600	4000		
Forward Voltage ₍₂₎	V_F	1	3.0	3.1	V	$I_F = 30\text{mA}$
		2	3.1	3.2		
		3	3.2	3.3		
		4	3.3	3.4		
		5	3.4	3.5		
		6	3.5	3.6		

Note.

1. Luminous intensity is measured with the accuracy of $\pm 10\%$.
2. Forward Voltage measure tolerance: $\pm 0.1\text{V}$.

Typical Electro-Optical Characteristics Curves

Relative Spectrum Distribution

IF=30mA, T_{Ambient} = 25°C

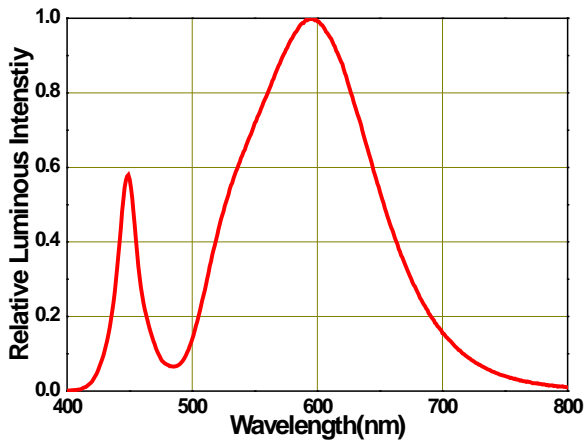

Forward Voltage vs Forward Current

T_{Ambient} = 25°C

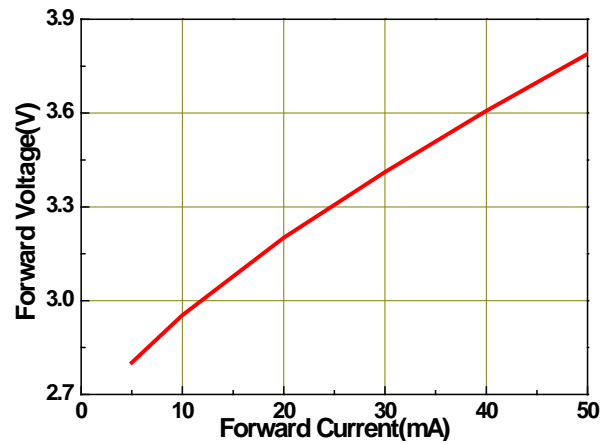

Relative Luminous Intensity vs Forward Current, T_{Ambient} = 25°C

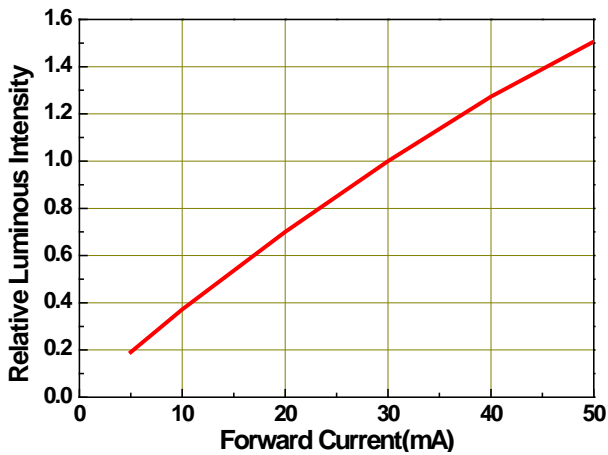

Forward Current Derating Curve

Derating based on T_{jmax} = 110°C

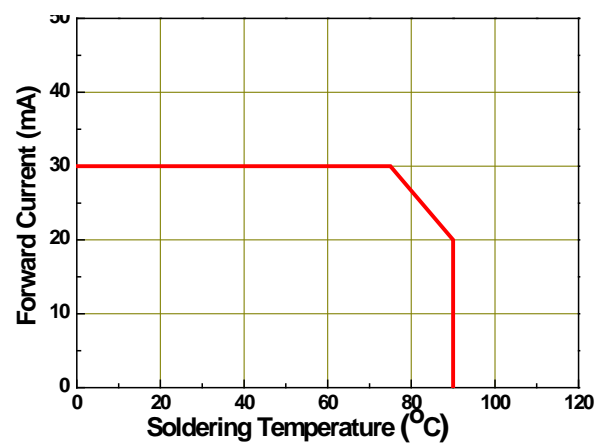

Typical Representative Spatial Radiation Pattern

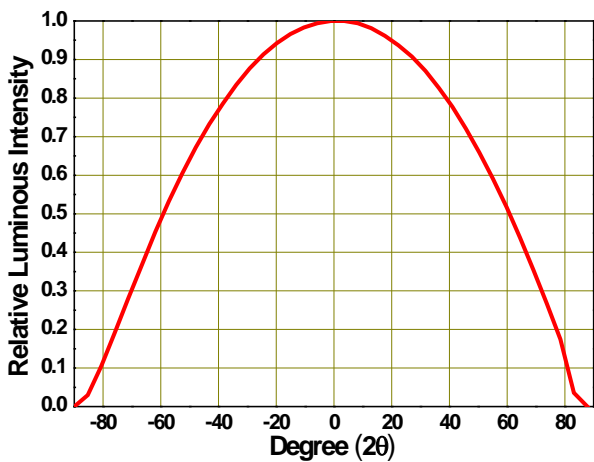

Note.

1. $2\theta_{1/2}$ is the off axis angle from lamp centerline where the luminous intensity is 1/2 of the peak value.
2. View angle tolerance is $\pm 5^\circ$

Chromaticity Coordinate Groups

Warm White

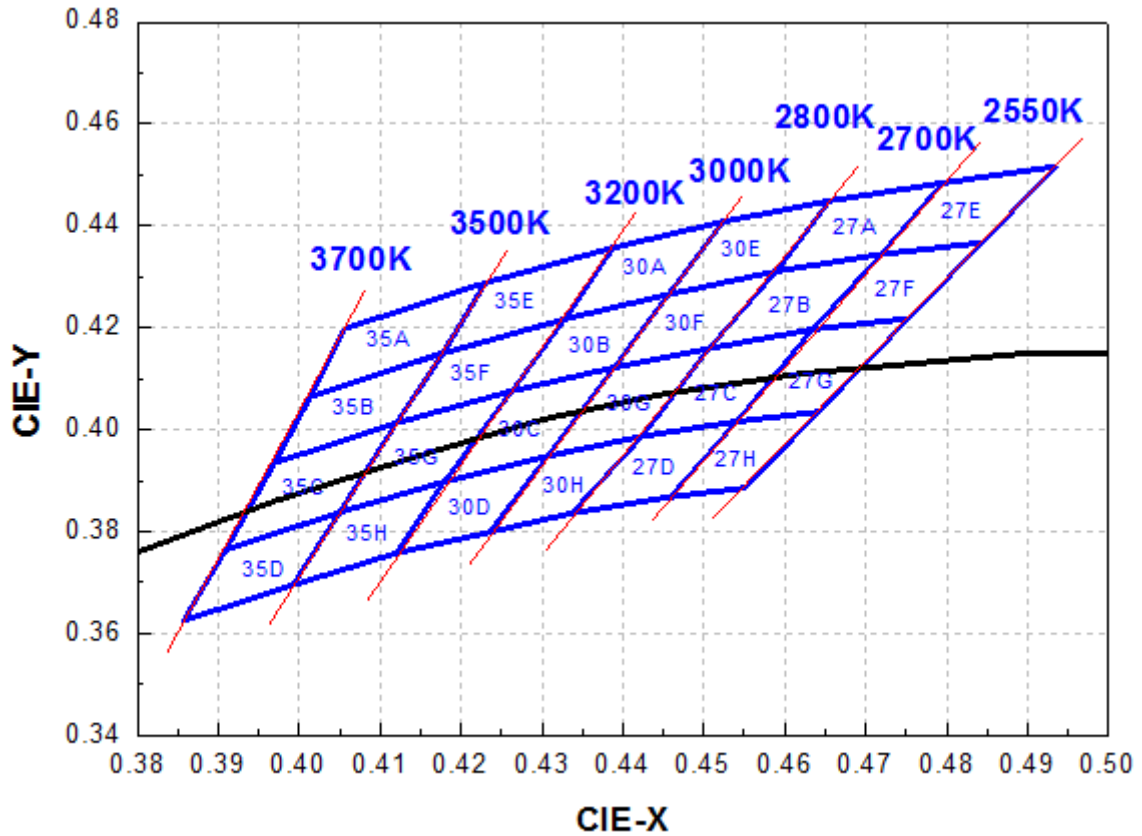

3500K											
Rank	CIE-X	CIE-Y	Rank	CIE-X	CIE-Y	Rank	CIE-X	CIE-Y	Rank	CIE-X	CIE-Y
35A	0.4056	0.4198	35B	0.4014	0.4065	35C	0.397	0.3935	35D	0.3909	0.3764
	0.4014	0.4065		0.397	0.3935		0.3909	0.3764			
	0.4177	0.415		0.412	0.4013		0.405	0.3838			
	0.423	0.4288		0.4177	0.415		0.412	0.4013			
35E	0.423	0.4288	35F	0.4178	0.415	35G	0.412	0.4013	35H	0.405	0.3838
	0.4178	0.415		0.412	0.4013		0.405	0.3838			
	0.4328	0.4217		0.4263	0.4076		0.4179	0.3898			
	0.4388	0.4357		0.4328	0.4217		0.4263	0.4076			

3000K											
Rank	CIE-X	CIE-Y	Rank	CIE-X	CIE-Y	Rank	CIE-X	CIE-Y	Rank	CIE-X	CIE-Y
30A	0.4388	0.4357	30B	0.4328	0.4217	30C	0.4263	0.4076	30D	0.4179	0.3898
	0.4328	0.4217		0.4263	0.4076		0.4179	0.3898		0.412	0.3758
	0.4456	0.4265		0.4389	0.4122		0.4307	0.3948		0.4235	0.3799
	0.4524	0.4408		0.4456	0.4265		0.4389	0.4122		0.4307	0.3948
30E	0.4524	0.4408	30F	0.4456	0.4265	30G	0.4389	0.4122	30H	0.4307	0.3948
	0.4456	0.4265		0.4389	0.4122		0.4307	0.3948		0.4235	0.3799
	0.459	0.4311		0.4506	0.4159		0.4424	0.3987		0.4336	0.3836
	0.4655	0.4449		0.459	0.4311		0.4506	0.4159		0.4424	0.3987
2700K											
Rank	CIE-X	CIE-Y	Rank	CIE-X	CIE-Y	Rank	CIE-X	CIE-Y	Rank	CIE-X	CIE-Y
27A	0.4655	0.4449	27B	0.459	0.4311	27C	0.4506	0.4159	27D	0.4424	0.3987
	0.459	0.4311		0.4506	0.4159		0.4424	0.3987		0.4336	0.3836
	0.4719	0.4344		0.4634	0.4197		0.4541	0.4016		0.4458	0.3868
	0.4795	0.4484		0.4719	0.4344		0.4634	0.4197		0.4541	0.4016
27E	0.4795	0.4484	27F	0.4719	0.4344	27G	0.4634	0.4197	27H	0.4541	0.4016
	0.4719	0.4344		0.4634	0.4197		0.4541	0.4016		0.4458	0.3868
	0.4844	0.4367		0.4753	0.4218		0.4642	0.4035		0.4552	0.3886
	0.4935	0.4516		0.4844	0.4367		0.4753	0.4218		0.4642	0.4035

Note.

1. CIE-X 、 Y measure tolerance: ± 0.01

Carrier Tape Dimensions

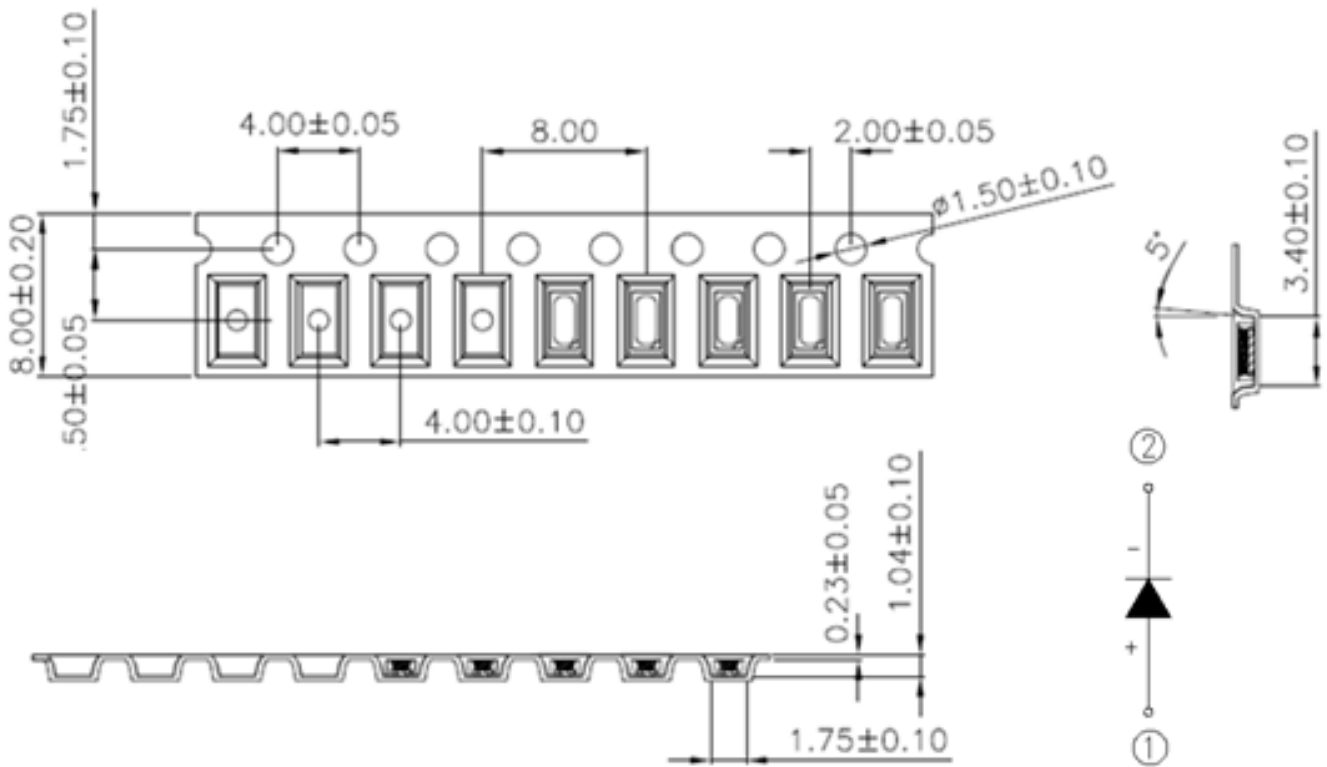

Reel Specification

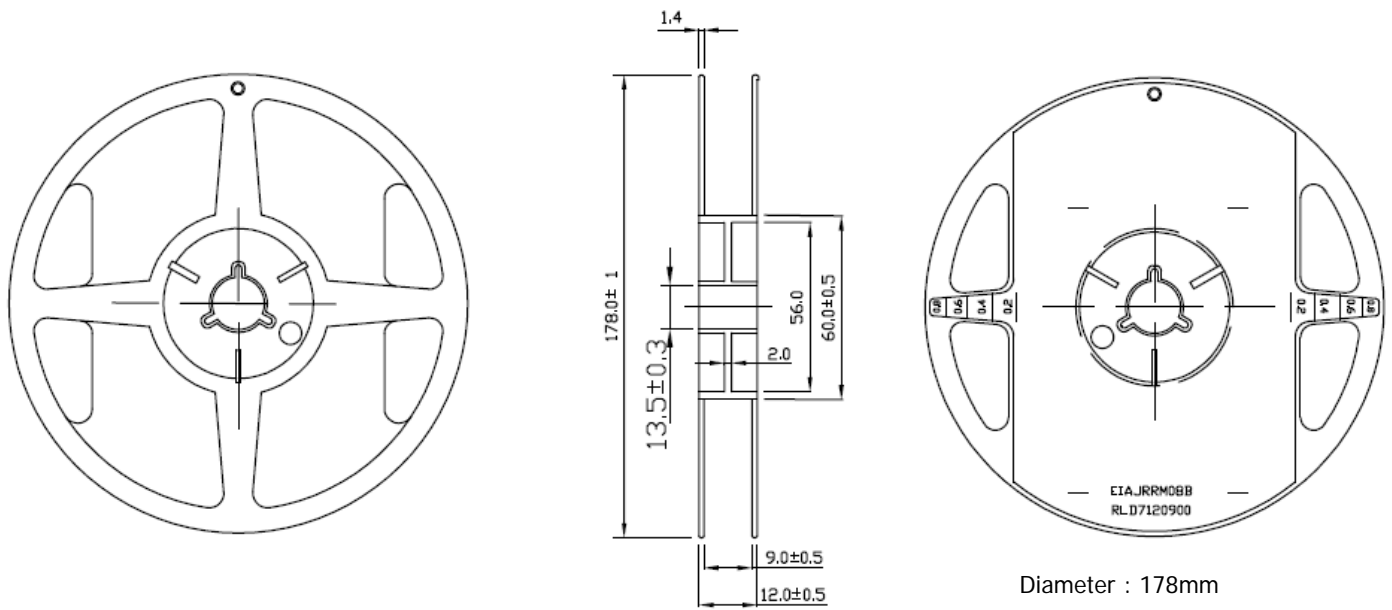

Diameter : 178mm

Width : 12mm

3014 \Rightarrow 3000 pcs/Reel

Reliability Test Items and Results

Stress Test	Stress Condition	Stress Duration
Room Temperature Operation Life, RTOL	Ta=25°C, If=30mA	1000 hours
High Temperature Operation Life, HTOL	Ta=65°C, If=30mA	1000 hours
Low Temperature Operation Life, LTOL	Ta=-40°C, If=30mA	1000 hours
High Temperature/High Humidity Operation Life, WHTOL	Ta=85°C, RH=85%, If=30mA	1000 hours
Thermal Shock	-40~125°C, 30min~30min	100 cycles

Failure Criteria :

1. Light output has more than 30% degradation than initial light output.
2. Forward voltage variation more than $\pm 20\%$.

Storage

- (1) Do not open moisture proof bag before the products are ready to use.
- (2) Before open the package. The LEDs should kept at 30°C and 90%RH or less
- (3) After open the package, the SMD LED should be kept at 28°C, 60%RH or less.
- (4) If the moisture absorbent material has faded away or the LEDs have exceeded the storage time, baking treatment should be performed using the following conditions.
Baking treatment: 60°C for 24 hours

Soldering

Manual Soldering (We do not recommend this method strongly) Soldering tin material: tin 6/4 alloy or contained Ag. To prevent cracking, please bake before manual soldering.

Keep the temperature on the edge of iron at 300°C Max.(25W)and apply for 3 seconds. If the temperature becomes higher, apply in a shorter time (1sec).

In manual soldering, take care not to damage the package especially terminal or resin.(Do not give stress to the product when soldering)

Do not use again if you remove the soldered product. It is recommended using an iron with a temperature control.

Reflow Soldering

Recommend tin glue specifications:

Melting temperature: 150~260°C

Contains: Sn96.5%,Ag3.0%,Cu 0.5% JIS Z 3282 TEST

Never take next process until the component is cooled down to room temperature after reflow

The recommended reflow soldering profile (measuring on the surface of the LED resin) is following

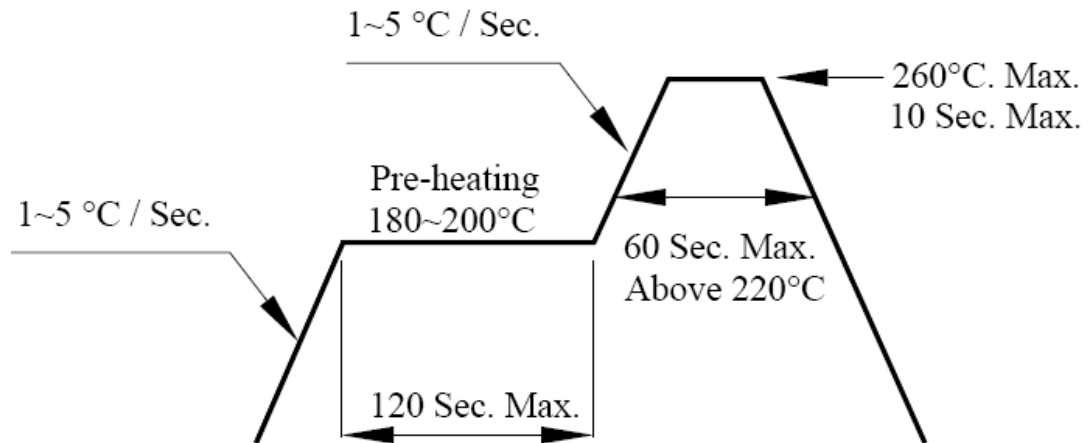

Cleaning

The conditions of cleaning after soldering:

An alcohol-based solvent such as Isopropyl Alcohol (IPA) is recommended.

Temperature Time : < 50°C 30sec, or <30°C 3min

Ultra sonic cleaning : < 15W/bath volume: 1 liter max

Curing: 100 max,<3min

Cautions of Pick and Place

It should be avoided to load stress on the resin during high temperature.

Avoid rubbing or scraping the resin by any object.

Electric-static may cause damage to the component. Please confirm that the equipment is grounding well. Using an ionizer fan is recommended.

Cautions of Design and Applications

It should be done to connect with a current-limiting serial resistor. Avoid to drive reverse voltage over the specifications on LED when ON/OFF

Any application should refer to the specifications of absolute maximum ratings.

The dimensions of the recommended soldering pattern may not meet every user. Please confirm and study first before designing the soldering pattern in order to obtain the best performance of soldering.

Do not contact with any component on the assembly board.